

# **F0-04RTD 4-CHANNEL RTD INPUT**

---



## **In This Chapter...**

Module Specifications .....	8-2
Connecting and Disconnecting the Field Wiring .....	8-4
Module Operation .....	8-6
Special V-memory Locations .....	8-7
Configuring the Module in Your Control Program .....	8-11
Negative Temperature Readings with Magnitude Plus Sign .....	8-15
Analog Input Ladder Logic Filter .....	8-18
RTD Burnout Detection Bits .....	8-20

## Module Specifications

The F0-04RTD 4-Channel Resistive Temperature Detector Input Module provides the following features and benefits:

- Provides four RTD input channels with 0.1 °C/°F temperature resolution.
- Automatically converts type Pt100Ω, jPt100Ω, Pt1000Ω, 10Ω Cu, 25Ω Cu, 120Ω Ni RTD signals into direct temperature readings. No extra scaling or complex conversion is required.
- Temperature data can be expressed in °F or °C, and as magnitude plus sign or 2's complement.
- Precision lead wire resistance compensation by dual matched current sources and ratiometric measurements. Works with three wire and four wire RTDs.
- The temperature calculation and linearization are based on data provided by the National Institute of Standards and Technology (NIST).
- Diagnostic features include detection of short circuits and input disconnection.

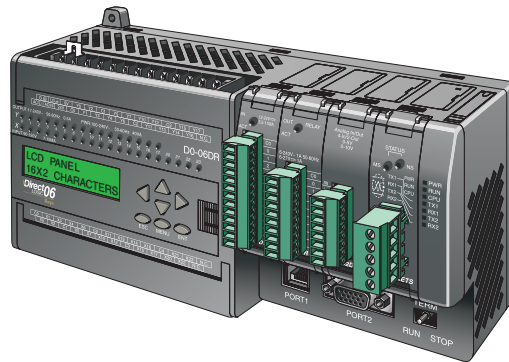
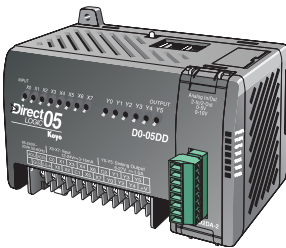

**NOTE:** The DL05 CPU's analog feature for this module requires **DirectSOFT32** Version 3.0c (or later) and firmware version 4.70 (or later). The DL06 requires **DirectSOFT32** version V4.0, build 16 (or later) and firmware version 1.50 (or later). See our website for more information: [www.automationdirect.com](http://www.automationdirect.com).

## Module Calibration

The module automatically re-calibrates every five seconds to remove any offset and gain errors. The F0-04RTD module requires no user calibration. However, if your process requires calibration, it is possible to correct the RTD tolerance using ladder logic. You can subtract or add a constant to the actual reading for that particular RTD. The actual reading can also be scaled to obtain the desired value using ladder logic.

## Input Specifications

The following table provide the specifications for the F0-04RTD Input Module. Review these specifications to make sure the module meets your application requirements.

Input Specifications	
Number of Channels	4
Input Ranges	PT100: -200.0 °C to 850.0 °C (-328 °F to 1562 °F) PT1000: -200.0 °C to 595.0 °C (-328 °F to 1103 °F) jPt100: -38.0 °C to 450.0 °C (-36 °F to 842 °F) 10Ω Cu: -200.0 °C to 260.0 °C (-328 °F to 500 °F) 25Ω Cu: -200.0 °C to 260.0 °C (-328 °F to 500 °F) 120Ω Ni: -80.0 °C to 260.0 °C (-112 °F to 500 °F)
Resolution	16 bit (1 in 65535)
Display Resolution	±0.1 °C, ±0.1 °F (±3276.7)
Absolute Maximum Ratings	Fault Protected Inputs to ±50VDC
Converter Type	Charge Balancing, 24 bit
Sampling Rate	140ms per channel
Linearity Error (End to End)	±0.05 °C maximum, ±0.01 °C typical
PLC Update Rate	4 channels/scan
Temperature Drift	15 ppm / °C maximum
Maximum Inaccuracy	±1 °C
RTD Excitation Current	200μA
Common Mode Range	0-5VDC
Notch Filter (Common Mode Rejection)	>50 db notches at 50/60Hz
Digital Input Points Required	None; uses special V-memory locations based on slot
Power Budget Requirements	70 mA @ 5VDC (supplied by base)
Operating Temperature	0 to 60° C (32 to 140° F)
Storage Temperature	-20 to 70° C (-4 to 158° F)
Relative Humidity	5 to 95% (non-condensing)
Environmental Air	No corrosive gases permitted
Vibration	MIL STD 810C 514.2
Shock	MIL STD 810C 516.2
Noise Immunity	NEMA ICS3-304
Replacement Terminal Block	D0-ACC-4
Wire Size Range & Connector Screw Torque	28 - 16 AWG; 0.4Nm; DN-SS1 Screwdriver Recommended

## Connecting and Disconnecting the Field Wiring

### Wiring Guidelines

Your company may have guidelines for wiring and cable installation. If so, you should check those before you begin the installation. Here are some general things to consider:

- Use the shortest wiring route whenever possible.
- Use shielded wiring and ground the shield at the transmitter source. *Do not* ground the shield at both the module and the source.
- Unused channels require shorting wires (jumpers) installed from terminals CH+ to CH– to COM.
- Do not run the signal wiring next to large motors, high current switches, or transformers. This may cause noise problems.
- Route the wiring through an approved cable housing to minimize the risk of accidental damage. Check local and national codes to choose the correct method for your application.

To remove the terminal block, disconnect power to the PLC and the field devices. Pull the terminal block firmly until the connector separates from the module.

You can remove the RTD module from the PLC by folding out the retaining tabs at the top and bottom of the module. As the retaining tabs pivot upward and outward, the module's connector is lifted out of the PLC socket. Once the connector is free, you can lift the module out of its slot.

Use the following diagram to connect the field wiring. If necessary, the F0-04RTD terminal block can be removed to make removal of the module possible without disturbing field wiring.

### RTD - Resistance Temperature Detector

Use shielded RTDs whenever possible to minimize noise on the input signal. Ground the shield wire at one end only, preferably at the RTD source.

#### Lead Configuration for RTD Sensors

The suggested three-lead configuration shown below provides one lead to the CH+ terminal, one lead to the CH– terminal, and one lead to the common terminal. Compensation circuitry nulls out the lead length for accurate temperature measurements.

Some sensors have four leads. When making connections, do not connect the second lead to the CH+ input; leave that lead unconnected.

Do not use configurations that lack the use of the same color lead to both the CH– and COM terminals. There is no compensation and temperature readings will be inaccurate.

This module has low RTD excitation current, worst-case dissipation with 100Ω RTDs connected is only 0.016mW.

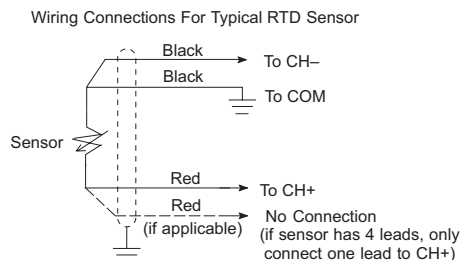

### Ambient Variations in Temperature

The F0-04RTD module has been designed to operate within the ambient temperature range of 0 °C to 60 °C.

Precision analog measurement with no long term temperature drift is assured by a chopper stabilized programmable gain amplifier, ratiometric referencing, and automatic offset and gain calibration.

### Wiring Diagram

Use the following diagram to connect the field wiring. If necessary, the F0-04RTD terminal block can be removed to make removal of the module possible without disturbing field wiring.

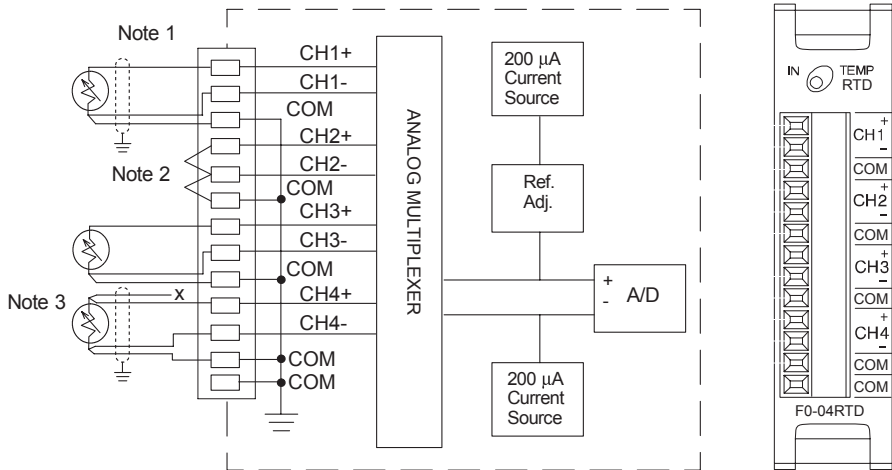

**Notes:**

1. The three wires connecting the RTD to the module must be the same type and length. Do not use the shield or drain wire for the third connection.
2. Unused channels require shorting wires (jumpers) installed from terminals CH+ to CH- to COM to prevent possible noise from influencing active channels. This should be done even if the unused channel is not enabled in the V-memory configuration.
3. If a RTD sensor has four wires, the plus sense wire should be left unconnected as shown.

# Module Operation

## Channel Scanning Sequence

The DL05 and DL06 read all four input channels data during each scan. The CPUs support special V-memory locations that are used to manage the data transfer. This is discussed in more detail on the following page, “Special V-memory Locations”.

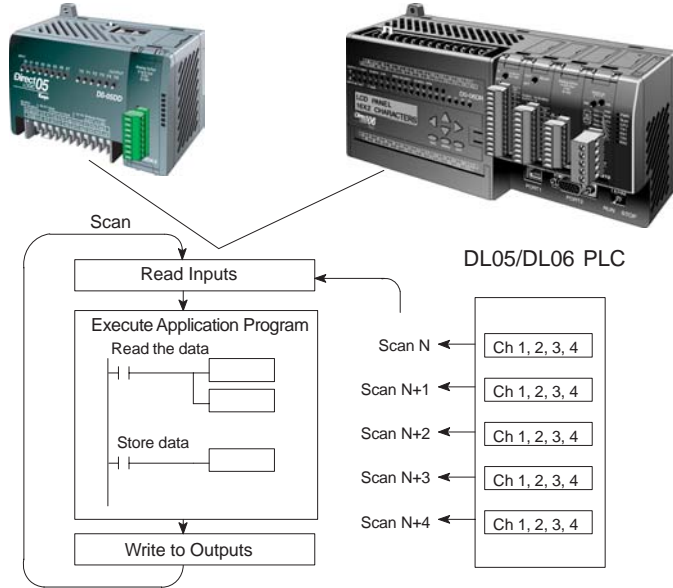

## Analog Module Update

Even though the channel updates to the CPU are synchronous with the CPU scan, the module asynchronously monitors the analog transmitter signal and converts the signal to a 16-bit binary representation. This enables the module to continuously provide accurate measurements without slowing down the discrete control logic in the RLL program.

The time required to sense the temperature and copy the value to V-memory is 140 milliseconds minimum to 560 milliseconds plus 1 scan time maximum (number of channels x 140 milliseconds + 1 scan time).

## Special V-memory Locations

The DL05 and DL06 PLCs have special V-memory locations assigned to their respective option slots. These V-memory locations allow you to:

- specify the number of input channels enabled and BCD/Binary data format
- specify the input pointer address
- specify the RTD input type
- specify the units code – temperature scale and data format
- specify burnout data value at burnout
- read module setup diagnostics

### Module Configuration Registers

The table below shows the special V-memory locations used by the DL05 and DL06 PLCs for the F0-04RTD module.

Module Configuration Parameters	DL05 and DL06 Option Slot				
	DL05 Slot	DL06 Slot 1	DL06 Slot 2	DL06 Slot 3	DL06 Slot 4
<b>A:</b> Number of Channels Enabled / Data Format	V7700	V700	V710	V720	V730
<b>B:</b> Input Pointer	V7701	V701	V711	V721	V731
<b>C:</b> RTD Type	V7703	V703	V713	V723	V733
<b>D:</b> Units Code	V7704	V704	V714	V724	V734
<b>E:</b> RTD Burnout Data Value	V7706	V706	V716	V726	V736
<b>F:</b> Diagnostic Error	V7707	V707	V717	V727	V737

### A: Number of Channels Enabled/Data Format Register

This V-memory location is used to define the number of input channels to be enabled and to set the channel data to BCD or binary format.

Number of Channels Enabled	Channel Data in BCD Format	Channel Data in Binary Format
<b>1 Channel</b>	K100	K8100
<b>2 Channels</b>	K200	K8200
<b>3 Channels</b>	K300	K8300
<b>4 Channels</b>	K400	K8400

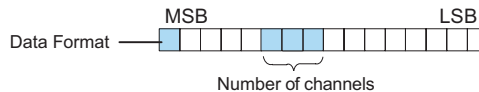

### B: Input Pointer Register

This is a system parameter that points to a V-memory location used for storing module channel input data. The V-memory location loaded in the input pointer V-memory location is an octal number identifying the first V-memory location for the input data. This V-memory location is user defined, but must use available consecutive V-memory locations. For example, loading O2000 causes the pointer to write Ch 1's data value to V2000/2001, Ch 2's data value to V2002/2003, CH 3's data value to V2004/2005 and Ch 4's data value to V2006/2007.



**Note:** Each channel's data value occupies two (2) consecutive V-memory locations. This allows for more than four (4) digits to be displayed if a BCD format for channel data is selected. For example: 1234.5 °F. A binary format for either a 15-bit magnitude plus sign or 16-bit 2's complement value will occupy the first V-memory location of the two V-memory locations assigned for the selected channel. Refer to the specific PLC's user manual being used for available user V-memory locations.

### C: RTD Type Selection Register

This V-memory register must be set to match the type of RTD being used. Use the table to determine your settings.

The module can be used with many types of RTDs. All channels of the module must be the same RTD type.

The default setting from the factory is Pt100Ω. This selects the DIN 43760 European type RTD. European curve type RTDs are calibrated to DIN 43760, BS1905, or IEC751 specifications which is .00385 Ω/Ω/°C (100 °C = 138.5Ω).

The jPt100Ω type is used for the American curve (.00392 Ω/Ω/°C), platinum 100Ω RTDs. The 10Ω and 25Ω RTD settings are used with copper RTDs.

RTD Type	Input Selection
Pt100 (European curve w/TCR = .00385)	K0
Cu10	K1
Cu25	K2
jPt100 (American curve w/TCR = .00392)	K3
Pt1000	K4
Ni120	K5

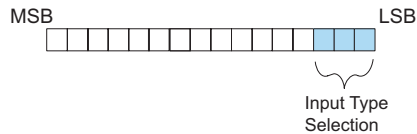



## D: Units Code Register

All RTD types are converted into a direct temperature reading in either Fahrenheit or Celsius. The data contains one implied decimal place. For example, a value in V-memory of 1002 would be 100.2 °C or °F.

All RTD ranges can include negative temperatures, therefore the display resolution is from -3276.7 to +3276.7.

Negative temperatures can be represented in either 2's complement or magnitude plus sign form. If the temperature is negative, the most significant bit in the V-memory location is set.

The 2's complement data format may be required to correctly display bipolar data on some operator interfaces. This data format could also be used to simplify averaging a bipolar signal. To view this data format in *DirectSoft32*, select Signed Decimal.

The bipolar input ranges may be converted to a 15-bit magnitude plus sign or a 16-bit 2's complement value.

Bit 0 = Temperature Scale

0 = Temp in degrees F

1 = Temp in degrees C

Bit 1 = Data Format

0 = Magnitude plus sign bit format

1 = 2's Complement format

Unit Code Register - Truth Table				
Temperature Scale	Data Format	Bit 1	Bit 0	Value
° F	Magnitude + sign bit	0	0	K0
° C	Magnitude + sign bit	0	1	K1
° F	2's Complement	1	0	K2
° C	2's Complement	1	1	K3

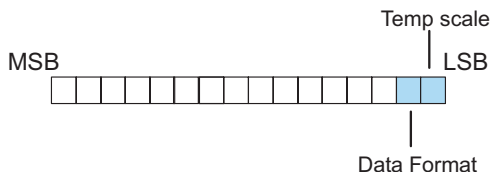

### E: RTD Burnout Data Value Register

This register is used to define either up scale or down scale channel values when a channel RTD burnout occurs.

Bit 0 = Up scale/down scale value at Burnout

0 = Up scale value at Burnout, 7FFF<sub>H</sub> (BCD/HEX) or 32767 (Binary)  
written to CH register

1 = Down scale value at Burnout: 0000<sub>H</sub> (BCD/HEX) or 0 (Binary)  
written to CH register

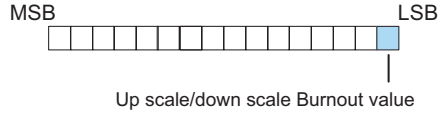

### F: Diagnostics Error Register

This register is used to determine whether the configuration of the module is valid or not.

Bit 0 = Diagnostic bit:

0 = Module setup is valid

1 = Module setup is not valid

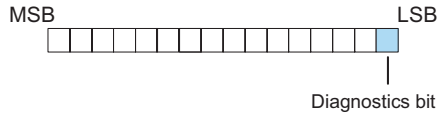

## Configuring the Module in Your Control Program

### DL05 Example 1

The example program below shows how to setup the F0-04RTD for 4 input channels enabled, use of a type Pt100 RTD on all 4 input channels, BCD channel data format, °F temperature scale, magnitude plus sign bit format, and with an up scale burnout value specified. Place this rung anywhere in the ladder program or in the initial stage if you are using stage programming instructions.

This is all that is required to read the temperature or voltage input data into V-memory locations. Once the data is in V-memory you can perform mathematical calculations with the data, compare the data against preset values, etc. V2000 is used in the example but you can use any user V-memory location.

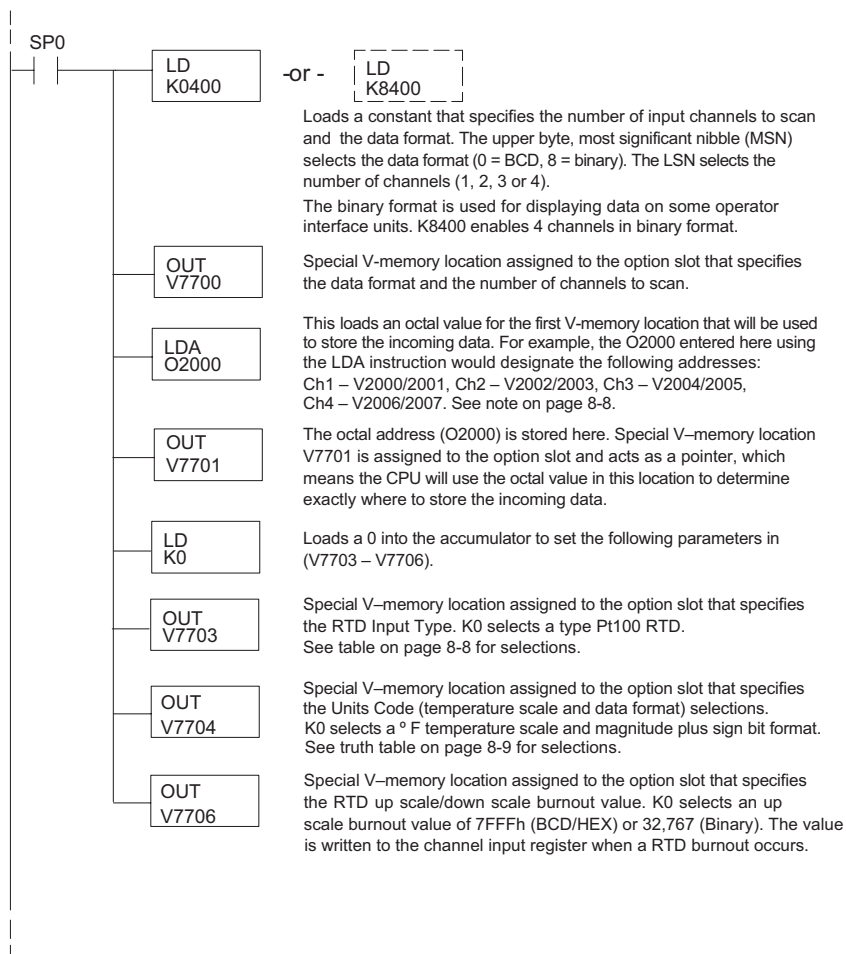

### DL05 Example 2

The example program below shows how to setup the F0-04RTD for 2 input channels enabled, use of a type Cu10 RTD on the first 2 input channels, BCD channel data format, °C temperature scale, 2's complement format, and with a down scale burnout value specified. Again, place this rung in the ladder program or in the initial stage if you are using stage programming instructions.

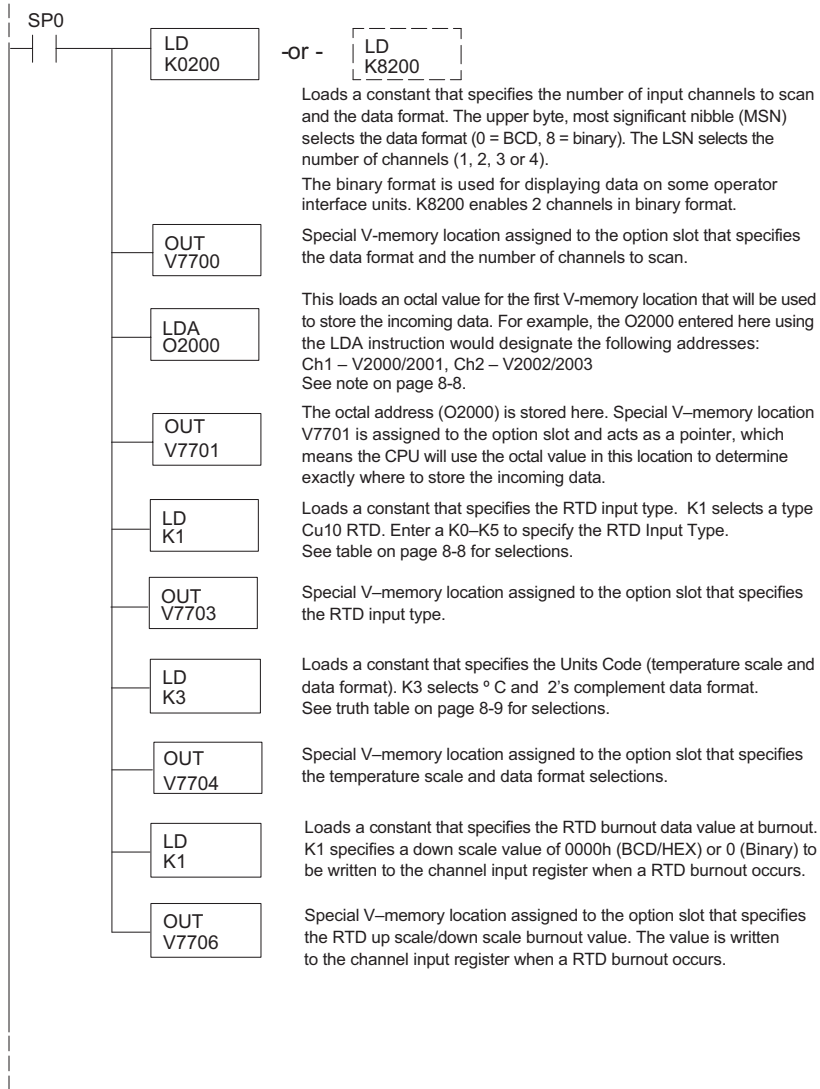

## DL06 Example 1

The example program below shows how to setup the F0-04RTD in option slot 1 for 4 input channels enabled, use of a type Pt100 RTD on all 4 input channels, BCD channel data format, °F temperature scale, magnitude plus sign bit format, and with an up scale burnout value specified. Use the table shown on page 8-7 to determine the pointer values if locating the module in any of the other slots. Place this rung anywhere in the ladder program or in the initial stage if you are using stage programming instructions.

This is all that is required to read the temperature or voltage input data into V-memory locations. Once the data is in V-memory you can perform mathematical calculations with the data, compare the data against preset values, etc. V2000 is used in the example but you can use any user V-memory location.

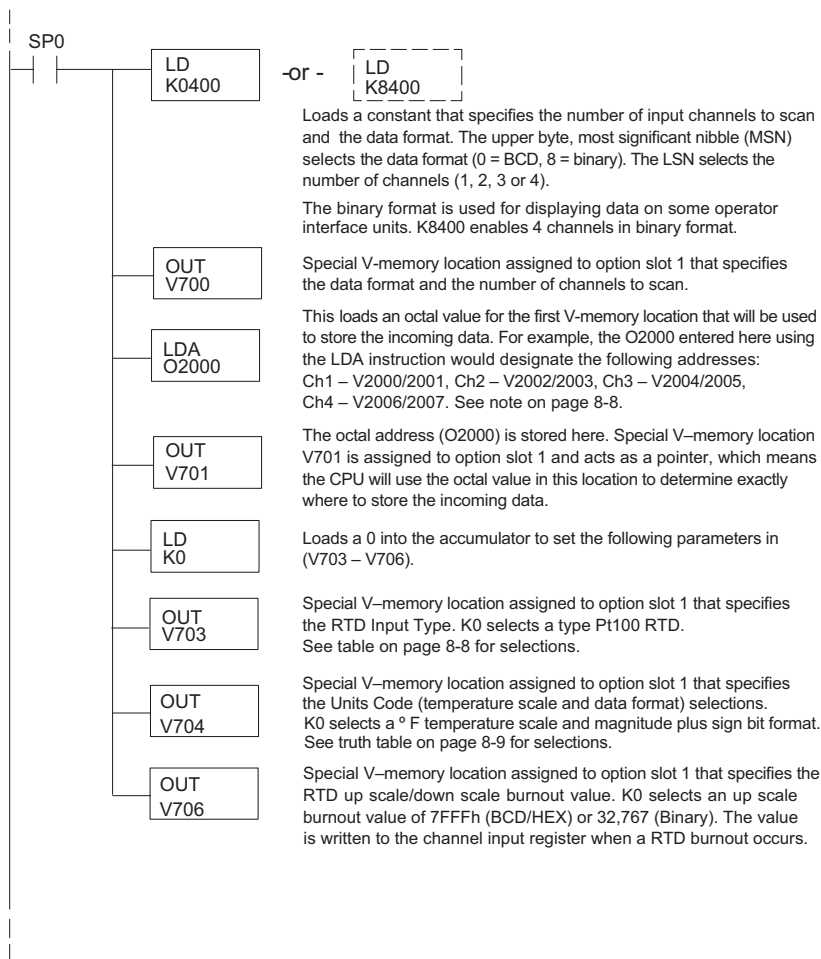

### DL06 Example 2

The example program below shows how to setup the F0-04RTD in option slot 2 for 2 input channels enabled, use of a type Cu10 RTD on the first 2 input channels, BCD channel data format, °C temperature scale, 2's complement format, and with a down scale burnout value specified. Use the table shown on page 8-7 to determine the pointer values if locating the module in any of the other slots. V-memory location V3000 is shown in the example, but you can use any available user V-memory location. Again, place this rung anywhere in the ladder program or in the initial stage if you are using stage programming instructions.

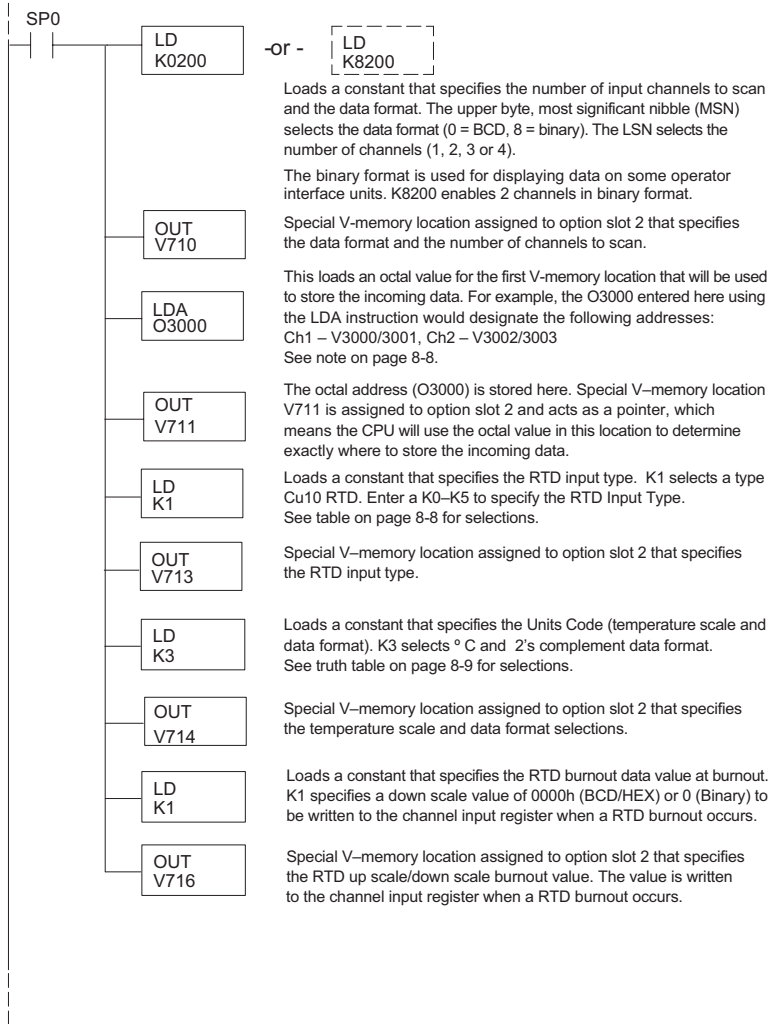

## Negative Temperature Readings with Magnitude Plus Sign

With bipolar ranges, you need some additional logic to determine whether the value being returned represents a positive temperature or a negative temperature. There is a simple solution:

- If you are using bipolar ranges and you get a value greater than or equal to 8000<sub>H</sub>, the value is negative.
- If you get a value less than or equal to 7FFF<sub>H</sub>, the value is positive.

The sign bit is the most significant bit, which combines 8000<sub>H</sub> to the data value. If the value is greater than or equal to 8000<sub>H</sub>, you only have to mask the most significant bit and the active channel bits to determine the actual data value.

The following two programs show how you can accomplish this. The first example uses magnitude plus sign (binary) and the second example uses magnitude plus sign (BCD).

Since you always want to know when a value is negative, these rungs should be placed before any other operations that use the data, such as math instructions, scaling operations, and so forth. Also, if you are using stage programming instructions, these rungs should be in a stage that is always active. Note: you only need this logic for each channel that is using bipolar input signals. The examples only show two channels.

### Magnitude Plus Sign (Binary)

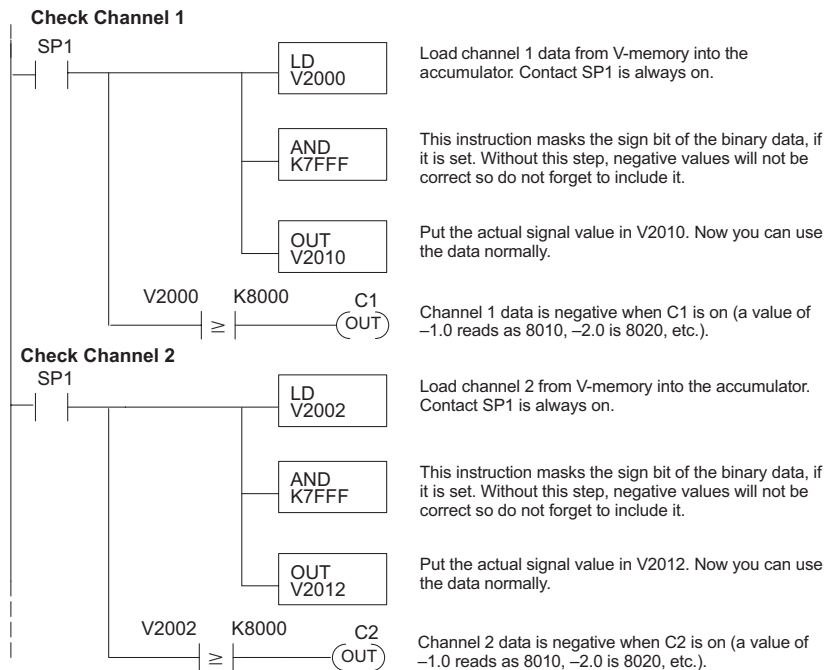

## Magnitude Plus Sign (BCD)

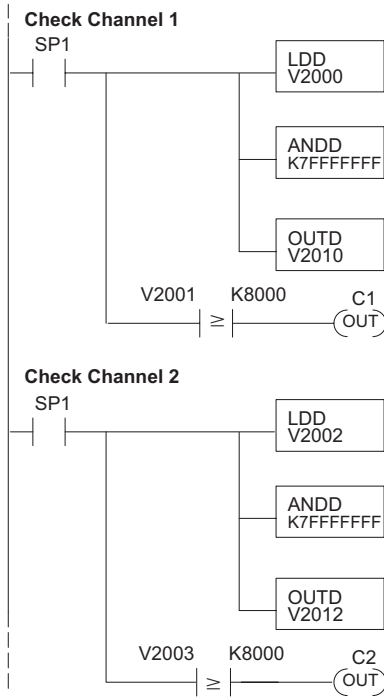

Load channel 1 data from V-memory into the accumulator. Remember, the data can be negative. Contact SP1 is always on.

This instruction masks the sign bit of the BCD data, if it is set. Without this step, negative values will not be correct so do not forget to include it.

Put the actual signal value in V2010. Now you can use the data normally.

Channel 1 data is negative when C1 is on (a value of -1.0 reads as 8000 0010, -2.0 is 8000 0020, etc.).

### Check Channel 2

Load channel 2 from V-memory into the accumulator. Remember, the data can be negative. Contact SP1 is always on.

This instruction masks the sign bit of the BCD data, if it is set. Without this step, negative values will not be correct so do not forget to include it.

Put the actual signal value in V2012. Now you can use the data normally.

Channel 2 data is negative when C2 is on (a value of -1.0 reads as 8000 0010, -2.0 is 8000 0020, etc.).



### Negative Temperatures 2's Complement (Binary/Pointer Method)

You can use the 2's complement mode for negative temperature display purposes, while at the same time using the magnitude plus sign of the temperature in your control program. The *DirectSOFT*32 element Signed Decimal is used to display negative numbers in 2's complement form. To find the absolute value of a negative number in 2's complement, invert the number and add 1 as shown in the following example:

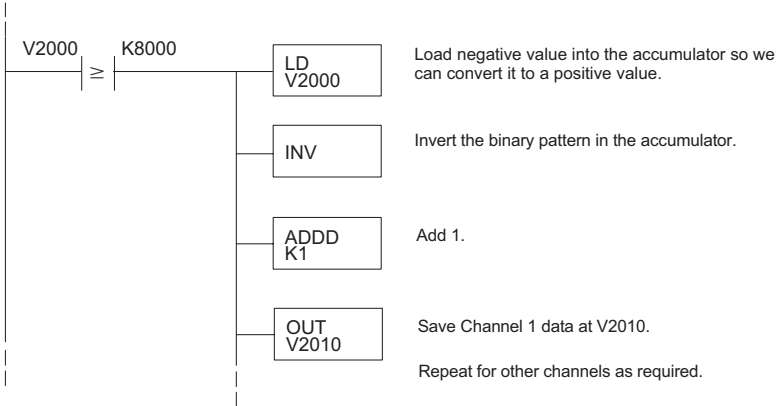

## Analog Input Ladder Logic Filter

### PID Loops / Filtering:

Please refer to the “PID Loop Operation” chapter in the DL06 or DL05 User Manual for information on the built-in PV filter (DL05/06) and the ladder logic filter (DL06 only) shown below. A filter must be used to smooth the analog input value when auto tuning PID loops to prevent giving a false indication of loop characteristics.

### Smoothing the Input Signal (DL06 only):

The filter logic can also be used in the same way to smooth the analog input signal to help stabilize PID loop operation or to stabilize the analog input signal value for use with an operator interface display, etc.



**Warning:** The built-in and logic filters are not intended to smooth or filter noise generated by improper field device wiring or grounding. Small amounts of electrical noise can cause the input signal to bounce considerably. Proper field device wiring and grounding must be done before attempting to use the filters to smooth the analog input signal.

### Using Binary Data Format

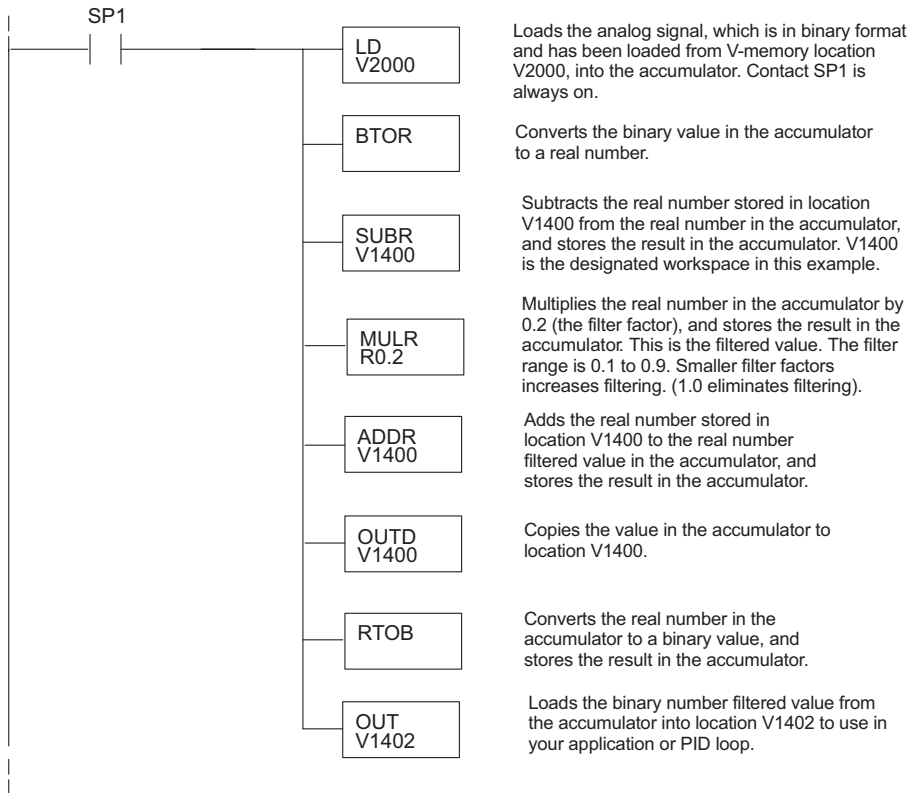



**NOTE:** Be careful not to do a multiple number conversion on a value. For example, if you are using the pointer method in BCD format to get the analog value, it must be converted to binary (BIN) as shown below. If you are using the pointer method in Binary format, the conversion to binary (BIN) instruction is not needed.

### Using BCD Data Format

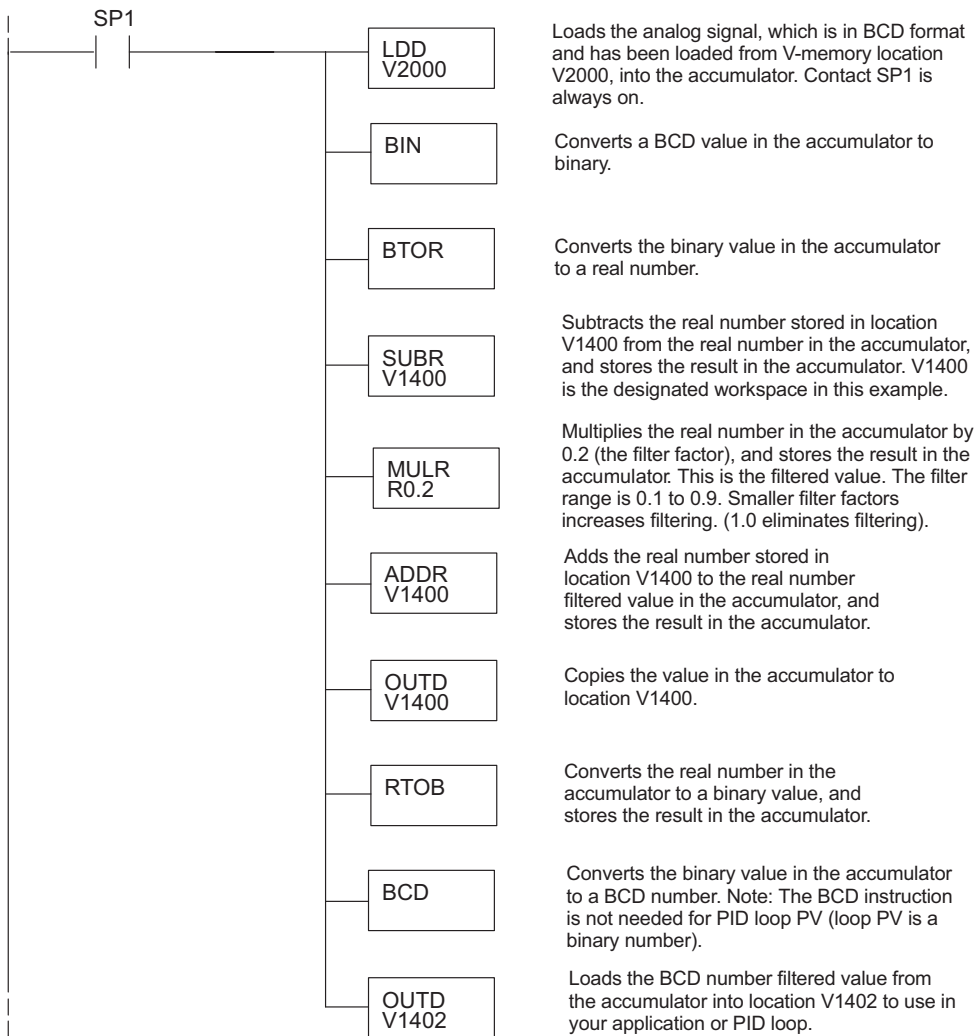

## RTD Burnout Detection Bits

### Special Relays Corresponding to RTD Burnouts

The following Special Relay (SP) bits can be used in your program to monitor for RTD burnout.

SP bit :

0 = RTD OK

1 = RTD burnout

Module Channel	DL05 and DL06 Option Slot				
	DL05 Slot	DL06 Slot 1	DL06 Slot 2	DL06 Slot 3	DL06 Slot 4
<b>Channel 1</b>	SP600	SP140	SP240	SP340	SP440
<b>Channel 2</b>	SP601	SP141	SP241	SP341	SP441
<b>Channel 3</b>	SP602	SP142	SP242	SP342	SP442
<b>Channel 4</b>	SP603	SP143	SP243	SP343	SP443